

## Profi-Line+ delivers the perfect combination, of quality, efficiency and value

**Our high-performance Profi-Line+ wheels have been developed to meet the changing needs of the agricultural sector, providing increased load capacity, higher operating speeds and longer life.**

With the need for tractors and trailers to carry ever-greater loads and work for prolonged periods of time, today's heavy-duty trailers require high-performance wheels; Profi-Line+ provides the ideal solution for these challenging applications.

Profi-Line+ meets the very specific requirements of heavy duty, high load-bearing flotation tyres, which may be subject to sustained periods of intensive use. With a loading capacity that is 20% higher and a lifetime five-times longer than standard flotation wheels, its unique design features deliver a number of operational and performance advantages:

- The 'bent-over' flange provides improved stability and affords greater protection to the tyre, both during operation and tyre mounting
- With a rim that is 10% thinner than the standard design, fuel consumption is improved
- Wheels are available with an extra connection in the rim for CTIS (Central Tyre Inflation System)
- Profi-Line+ wheels are high-spot marked, ensuring they are suitable for speeds up to 80 km/h\*
- For the most severe and demanding applications, the option of up-grading to stronger discs is available
- An optional valve guard may be fitted to provide even greater protection

With its elegant design and protected surface, Profi-Line+ also looks great and with a surface durability of over 1,400 hours (salt spray test), it will stay looking great for many years.

In summary, Profi-Line+ delivers the perfect package to meet the demands and challenges faced by owners and operators in the agricultural sector, delivering outstanding efficiencies through a combination of low process costs, assured reliability, low weight, low maintenance and long-life.

For more information or to discuss your own specific requirements, please contact us on [sales@gknwheels.com](mailto:sales@gknwheels.com). We would be delighted to help.



Photography: Krampe Fahrzeugbau GmbH

## Profi-Line+ Sizes

Width	Diameter	Width	Diameter	Width	Diameter
16.00	22.5	20.00	26.5	20.00	30.5
20.00	22.5	24.00	26.5	24.00	30.5
24.00	22.5	28.00	26.5	28.00	30.5

\*on request, available for speeds up to 100km/h

## PROFI-LINE+ - HIGHER LOAD CAPACITY

With a wider bead area and symmetrical rim, the Profi-Line+ from GKN offers a five-fold increase in fatigue life.

Designed to cope with heavier loads and high speeds of up to 80 km/h\*

Double well radius

- > Lower material stress
- > Higher loading capacity
- > Longer lifetime

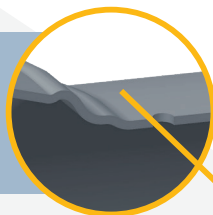

Bent over flanges

- > Tyre protection
- > Higher stability

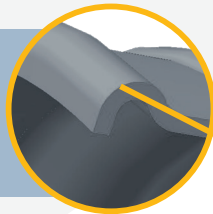

Valve guard (optional)

- > Valve protection

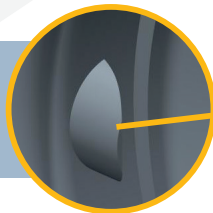

Wider bead

- > Optimised for CT-Tyres

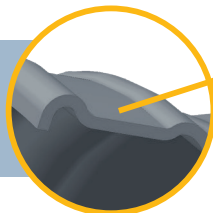

10% thinner rim

- > Higher loading capacity
- > Lower fuel consumption



### Highlights >

- > Load capacity + 20% in comparison with standard design
- > Surface durability >1400h
- > High Spot Marking
- > Lifetime over five times longer
- > Lower weight
- > Unique design - 40% lower stress
- > Wide flanges to protect VF tyre tech
- > Approved for 100 km/h\*
- > Connection to Central Tyre Inflation System option

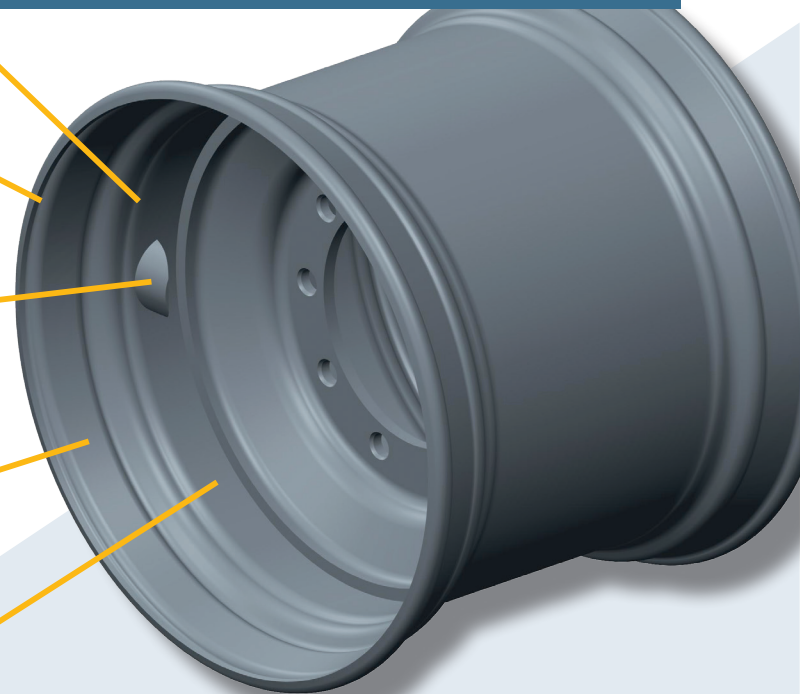

\*on request, available for speeds up to 100km/h